

# Stroboscope

## XE-H, Digital, Xenon



LB3809-001

### The IEC Design Has Many Special Useful Features:

- Microprocessor based design for reliability.
- Extremely accurate and absolutely stable.
- Very high resolution.
- Crystal locked frequency - calibration is not required.
- Bright digital LED display for easy reading in darkness.
- Downward viewing of digital display for ease of operation.
- Very bright Xenon flash output.
- Display either in Flashes per second or Revs per minute.
- Flash brightness self-adjusts at all frequencies.
- One single broad range from 1Hz to 300Hz frequency (60 to 18,000 RPM)..
- Very robust design, suitable for workshop abuse.
- Operates from 220/240V.AC. mains at 50/60 Hz.
- Can be triggered by remote contact closure or voltage signal source.
- Includes convenient digital TACHOMETER function.
- Modern press button control of all functions:
- Selection for flash ON/OFF.
- Selection for flash trigger by internal control (normal operation)
- Selection for flash trigger from an external signal
- Selection for flash synchronise to mains frequency.
- Carry handle can be used as tilt support beneath the housing.
- Designed and manufactured in Australia.

Length: 180mm	Width: 300mm	Height: 35mm	Weight: 350g
---------------	--------------	--------------	--------------

**INDUSTRIAL EQUIPMENT & CONTROL PTY.LTD.**

61-65 McClure St. Thornbury. 3071 Melbourne. Australia  
 Tel: 61 (0)3 9497 2555 Fax: 61 (0)3 9497 2166 www.iecpl.com.au



## Description:

The unique IEC Digital Xenon Stroboscope is specially designed for the mechanical engineer or consultant and for student use in the classroom.

The bright flashing light is pointed at a device in motion and, regardless of the type of motion, when the visible image appears to be stationary, the exact speed of the motion is displayed on the digital display.

Sometimes, rather than measuring the speed of a moving object, only the visual examination of the 'Frozen' Image is required. The large reflector ensures this feature is effective.

The instrument is microprocessor controlled and is crystal locked. The accuracy is exact and the stability is absolute for the life of the instrument. Calibration controls are not required

## Features:

The large 150mm diameter reflector provides a bright flash that covers a wide area. The flash intensity automatically adjusts to provide the best brightness as the flash rate is changed. Range: 1.000Hz to 300.0Hz (60.00RPM to 18,000RPM).

All controls are press by button and the memory feature ensures that when the instrument is powered up, the flash rate is initially the same as the rate that was used at the moment it was previously shut down.

The IEC Stroboscope is complete with a carry handle that can be used also as a tilt support for aiming the stroboscope to a target.

The model "XE-H" (LB3809-001) provides a socket to accept an extension flash torch or extension flash head to run by cable to be remote from the main instrument.

## Operation of Instrument:

### Power Up:

When 220/240V.AC. 50/60Hz. mains power is first applied, the LED display will show 'IEC' then a quick display test. The display will then show the setting that was last used on the Stroboscope the last time it was used. On power up, the flashing will be OFF. The small LED indicating 'flash off' will be ON. To initiate flashing, press the FLASH ON/OFF button momentarily. NOTE: Accuracy and stability of the instrument, long or short term is absolute and future calibration is not required.

### Adjust Flash Frequency:

To raise the flash rate, press the UP ARROW button. Each press of the button increments the flash rate only slightly by one least significant digit. When the button is held depressed, after a very short delay, the rate increments faster. If the DOWN button is pressed while still depressing the UP button, the frequency rises very quickly. The same is true for the DOWN ARROW button.

### To Stop Flashing:

Momentarily press the button marked FLASH ON/OFF. The flashing will stop but the display will remain active. Note the display window indicates and a small LED on the panel reminds the user that the flashing has been switched off. If desired, the new flash frequency can be preset with the flashing off. When ready, press the button momentarily again and the flashing will be ON.

### The XENON Flash:

The Xenon flash tube is limited to a maximum average power dissipation of about 25 watts. Internally, the brightness of the flash is automatically altered with flash frequency to obtain maximum flash brilliance at any frequencies. Flash duration is about 20-50 microseconds at low frequencies (brightest flash) and about 10 microseconds at high frequencies.



## Modes:

The MODES can be selected ONLY when the flash is off.

### Internal:

Means that the flashing of the Stroboscope is controlled by the press buttons on the panel.

### External:

Means that the flashing is controlled by external pulse source connected to the 4mm sockets provided.

### Mains Lock:

Means that the display will indicate and the flash will occur exactly at the rate of the mains frequency.

## Units:

The UNITS can be selected ONLY when the flash is off.

### Hz:

Means Hertz which is the unit of frequency of events occurring per second. In this case it means Flashes per second.

### RPM:

Means revolutions per minute of the device being observed. Used mainly in engineering and automotive fields.

## Socket for Trigger and Measurement of External Frequencies.

The two 4mm sockets accept signals for triggering the flash. The voltage present at these sockets is about 750 millivolts.

**Signal required:** A short circuit of the two sockets will produce a single flash so that a simple external mechanical switch can trigger the strobe. A moving device can be arranged to operate a simple switch and the Stroboscope flash will be synchronised exactly with the motion. The speed of the motion will be displayed in the selected unit and the image viewed will be perfectly stationary.

Alternatively, an electrical signal or square wave trigger pulse driving from less than 500mV low rising to 1.5V high (up to 20V.max) will also trigger the flash. Duration of signal should be at least 1 millisecond.

## Taking Measurements: Techniques

### Tachometer:

If an external signal is used to trigger the Xenon flash, the digital display also indicates the flash rate being triggered. If the flash is turned OFF, the display continues to display the flash rate either in RPM or Hz as selected. This means the instrument can be used to produce a perfectly synchronised "Frozen Image" or can be used as a Tachometer from an external signal source.

### Multiple Images:

In the case of symmetrically shaped objects such as a fan or a hexagonal nut and almost all wheels and gears, care must be taken to ensure that the stationary image seen is caused by one single flash per revolution.

Consider a four bladed fan rotating at 3000 RPM or 50 RPSec. A stationary image will be observed when the flash frequency is 50 per second, that is one flash per revolution. Since there are four symmetrically positioned blades, there will be another stationary image at 100 flashes/second (each half turn) and also at 200 flashes/second (each quarter turn).

To overcome this confusion, a temporary mark with adhesive tape or chalk should be placed on one blade to upset the optical symmetry so that multiple images can easily be distinguished from the 1:1 direct reading image.

However, after marking the blade, it will be found that another stationary image will be found at 25 FPS (two turns per flash) and 16-2/3FPS (three turns per flash) and 12-1/2 FPS (four turns per flash) and so on.



## The 'Golden' Rule:

Using a distinguishing mark on a rotating object, viewed from the front, the first single image observed whilst reducing the flash rate from maximum is the true direct reading image.

### Using Multiple Images:

#### Higher Frequency:

At high flash frequencies you can see double and triple and higher image multiples because the flash may occur several times per single motion.

Sometimes, when the object is slow in motion, the stationary image might appear difficult to view especially in illuminated surroundings.

If the frequency is raised to two or three multiple images, the image will appear with less flicker and will be more steady to the eye.

The true speed is the displayed reading divided by the number of images.

#### Lower Frequency:

If the flash rate is slower than the moving object, the object could be moving several times between each successive flash but the image will appear to be stationary. This can be confusing.

To be sure the image you see is the true 1:1 synchronised image, always begin at a higher frequency and adjust downwards towards the actual frequency. Then, the first single image you see is the true 1:1 image synchronised with the moving object.

In some cases the moving object might be much faster than the range of the instrument (300/second or 30,000 RPM). The RPM can be extended up to about 250,000 RPM by using the following technique:

Run the Stroboscope at maximum frequency and reduce it slowly to find the first stationary image. Note the reading. Continue to reduce the frequency to the NEXT stationary image. Note the reading. Apply the following formula:

$(\text{lower reading} / \text{difference between readings}) \times \text{higher reading}$

#### Example:

An object rotating at very high speed.

First two stationary images were found at instrument readings of 17,000 RPM and 13,600 RPM.

The difference between the readings is 3,400

True speed of object is:

$(13,600 / 3,400) \times 17,000 = 68,000 \text{ RPM}$

## Spares:

PA3810-002 Xenon Flash Tube



## Notes for Advanced Model Only: LB3809-001 (Model 'XE-H')

The Advanced model STROBOSCOPE can also:

- Run a remote Xenon flash head or torch by cable connection.
- Run a very small mini slave LED on flexible cable.
- Accepts external trigger signals via both the 4mm sockets and the interface socket.

### Remote Xenon Torch or Flash Head:

The advanced model Stroboscope is fitted with a 4 pin DIN type socket for an extension flash head or flash torch. When plugged into this socket, the internal flashing stops and the flashing of the remote device begins.

PA3812-003 Remote Xenon flash head  
PA3812-004 Slim flash torch

### Interface Socket:

The advanced model Stroboscope is fitted with a 15 pin 'D' connector which accepts cables for special functions.

The socket can directly power up and operate the IEC giant digital remote display unit for long distance viewing (LB1675-001).

The socket also provides:

- 12V.AC at 250mA or 12V.DC. at 10mA for powering external trigger circuits.
- Accepts signals for triggering the flash from external sources.
- Accepts remote press button flash ON/OFF control.
- Drives a single remote LED which flashes as a micro stroboscope extension torch.  
For advanced model stroboscope only "XE-H" LB3809-001

## Electrical Connections

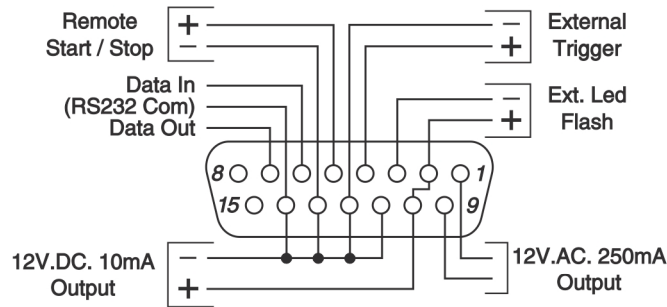

### Cables For Connecting Remote Devices:

#### Extension LED Flash

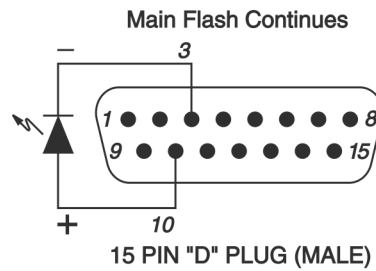
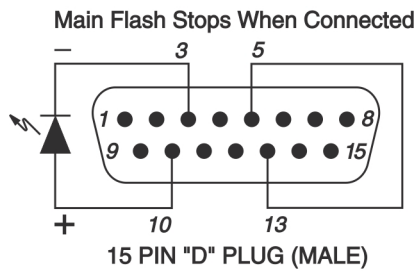

#### External Trigger

Contact Closure Or Volts Pulse  
Signal: > 1.5V (20V. MAX.) High < 500mV Low

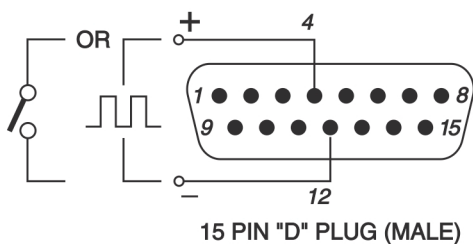

#### Remote Start / Stop

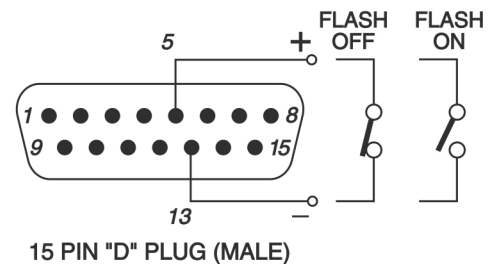

Designed and manufactured in Australia

**INDUSTRIAL EQUIPMENT & CONTROL PTY.LTD.**

61-65 McClure St. Thornbury. 3071 Melbourne. Australia  
Tel: 61 (0)3 9497 2555 Fax: 61 (0)3 9497 2166 www.iecpl.com.au