

# The 'HODSON' Motor Kit

## Set of 2

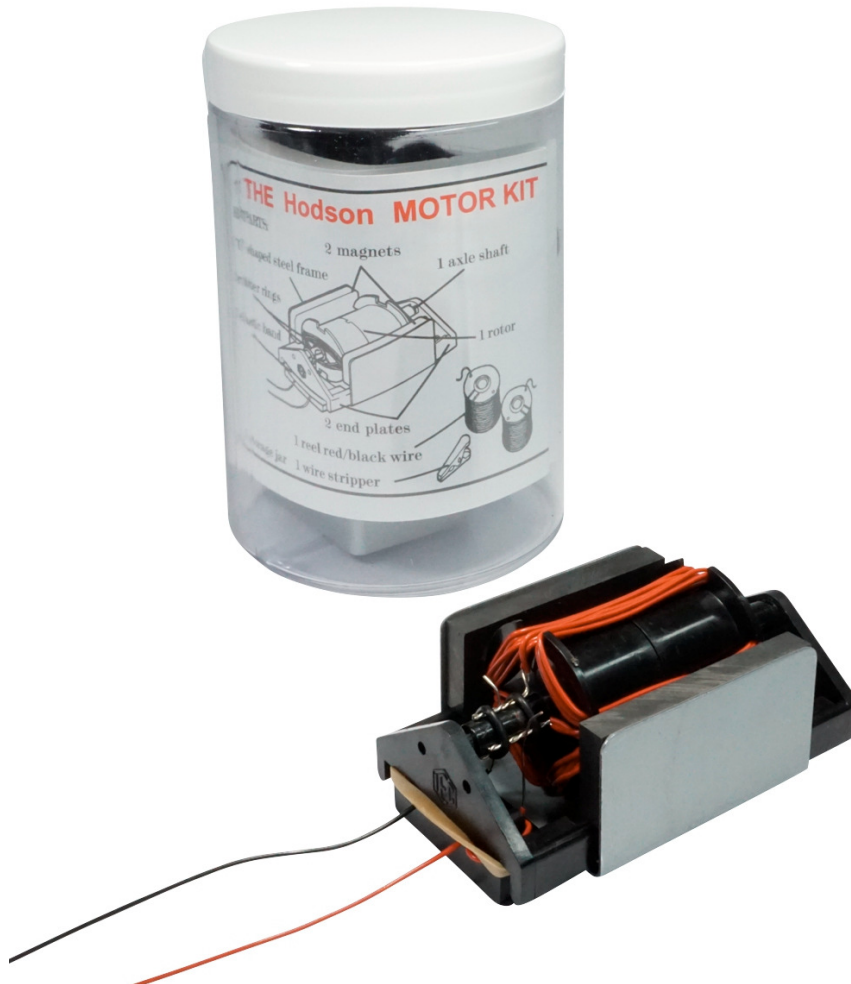

**EM2193-201**

### Description:

All the kit parts to make one motor are packed in a strong transparent container with a screw cap. The student winds the rotor, makes the commutator, makes the brushes and assembles the frame, the magnets and the whole motor in a very short time.

The student can wind different types of windings on the rotor. The options are: Single coil, double coil or four coils. This feature permits a better understanding of the principles of the electric motor and commutation. The motor can run either on DC or AC, but normally a 'D' size dry cell or a power supply set to 2V.DC. is used.

When 1-1/2 volts is applied to the brushes, the motor runs very reliably and the power or torque can perform useful tasks. The finished motor can be picked up and carried around while it is running without any risk of it falling apart.

Size & Weight for Each Motor Kit	Diameter: 80mm	Height: 122mm	Weight: 250g
----------------------------------	----------------	---------------	--------------

**INDUSTRIAL EQUIPMENT & CONTROL PTY. LTD.**

61-65 McClure St. Thornbury. 3071 Melbourne. Australia

Tel: 61 (0)3 9497 2555 Email: [iec@iecipl.com.au](mailto:iec@iecipl.com.au) [www.iecipl.com.au](http://www.iecipl.com.au)

1

## Kit Contents:

Each Electric Motor Kit Consists of:

- 1x Steel 'U' shaped frame
- 1x Rotor (two half rotors clicked together)
- 1x Axle shaft
- 2x Magnets
- 2x End plates, plastic
- 4x Rubber rings to hold commutator wire loops in place (including 2 spares)
- 2x Reels of insulated wire (1x red and 1x black)
- 1x Wire stripper (alligator clip)
- 2x Elastic band to hold motor together (including 1 spare)
- 1x Instruction card for student
- 1x Storage container jar or bag, transparent plastic.

Each pack of motors is supplied with this book of instructions and a few suggested experiments for the teacher. Many more experiments can be devised. Each separate motor has its own card of assembly instructions for the students. The student can assemble the motor by using the student instructions, but the teaching of the principles should be presented by the teacher.

Motors are driven usually by a single 'D' cell or from a power supply set at about 2 volts DC. There is sufficient room in the container for a 'D' cell (not supplied by IEC) to be packed and stored in the jar with the assembled motor after use.

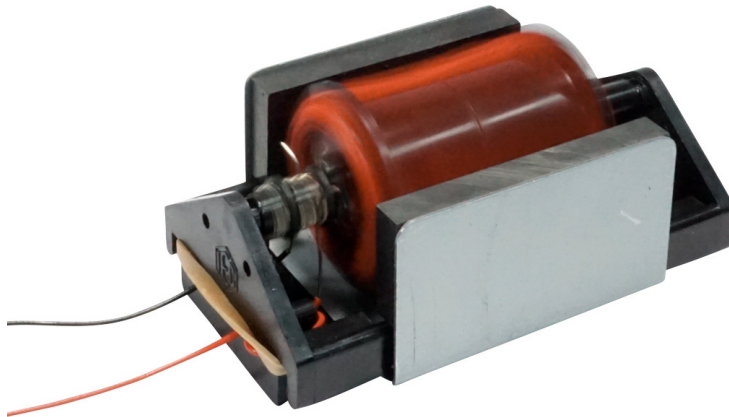

## Motor Assembly: (as card provided in the kit.)

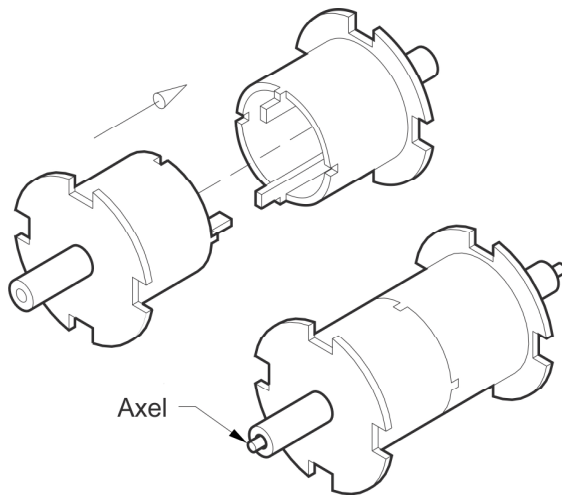

**Rotor Assembly**

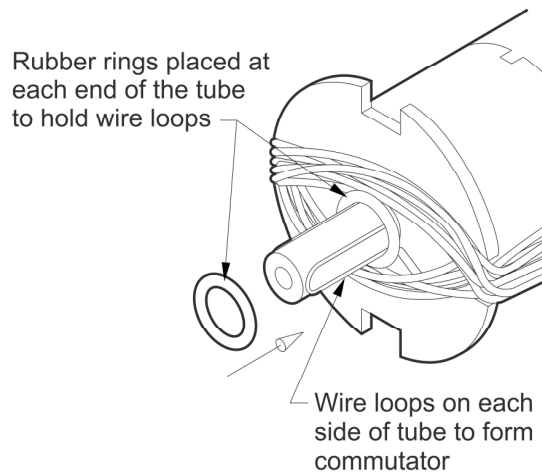

**Single Coil Winding**

Assemble Rotor by aligning the two halves of the rotor and pressing them together until they 'click'. Fit the Axle Shaft through the rotor to check that the rotor spins freely on the shaft.

Wind a Single Coil rotor as shown. Wind a bundle of about 10 or 12 turns with about half the turns either side of the bearing tube. Skin about 25mm of plastic off the start and finish of the wire and bend the bare wire into a loop about 4mm wide and 10mm long. Position the start and finish loops opposite each other and in line with the coil bundles. Hold the two loops in place by stretching the two rubber rings over the wire loops with maximum space for the brushes to make contact between them. These loops are called the 'commutator'.

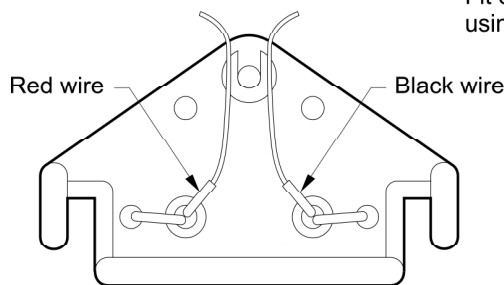

**End Plate showing wire 'brushes'**

Fit ends to frame using elastic band

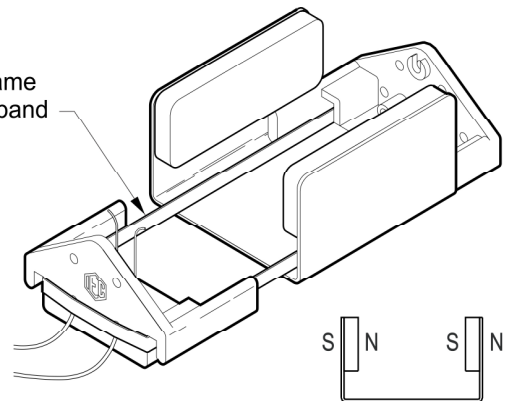

**Assembly showing elastic band**

Pass a RED wire through tube on one side of the end piece, loop it back through the other hole and back through the tube again and pull tightly to hold the wire firmly in place. Repeat for the other tube, but with BLACK wire. Skin the ends then bend and curve them as shown so they are about 4mm apart. When the rotor is slid into position, these wires will be pushed apart so they will be rubbing against the wire loops on the rotor to form 'brushes'.

Place the elastic band in the location slots provided in both plastic ends and separate them to stretch the band through the 'U' shaped frame. Engage the two ends to slip over the edges of the frame so that they lock into place. Place the two magnets into position with opposite poles facing and press them down to rest on the plastic rails coming from each end piece.

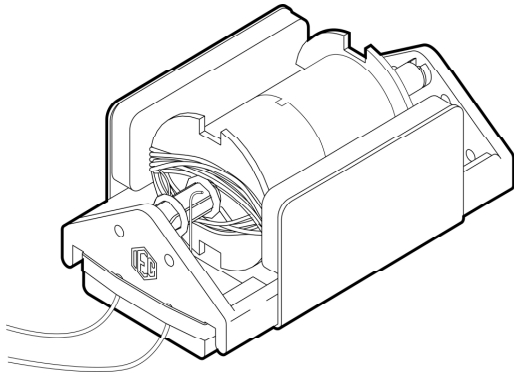
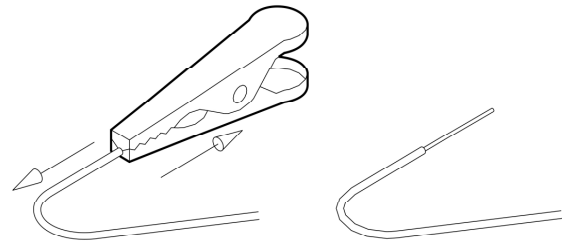
**Assembled Motor****Wire Skinner**

Take the rotor with its axle shaft fitted, pull one plastic end away from the frame slightly and slide the axle vertically down between the two ends and into the two bearing holes. While sliding the rotor down and into position, the two wires (brushes) will be forced apart slightly by the rotor so that they will rub gently on the rotor's wire loops (commutator) to make good electrical contact as the rotor spins.

The above sketch shows a simple single coil rotor with a skinned loop formed on each end of the coil. The other sketch shows how to use an 'Alligator Clip' as a wire skinner.

Be sure the motor spins freely and check that the two wire brushes are springing together and rubbing on the commutator. Skin the other ends of the red and black wires and connect them directly to a 1-1/2V 'D' size dry cell. If the rotor does not immediately turn, it might need a spin with the finger to start the motion. If still not successful, check that the magnet poles are north pole facing a south pole and check the brushes are rubbing on the loops.

## Summary of Assembly Steps:

1. Align and press the two halves of the rotor together until they 'click'.
2. Insert axle to be sure the rotor spins freely on it.
3. Remove the axle and wind the coil with either red or black wire.
4. Form the commutator and hold in place with 2 rubber rings.
5. Thread wires through end plate and form the brushes with red & black wire.
6. Fit the two ends to the metal frame with the elastic band.
7. Fit the two magnets with opposite poles facing each other and slide down firmly.
8. Fit the axle and fit the rotor between the ends and between the brushes.
9. Be sure the two brushes are pressing gently against the commutator loops and be sure the rotor runs free with the brushes positioned between the rubber rings.
10. Connect a 1.5V 'D' battery or 2.0V.DC. power supply to the red and black brush wires to see the rotor spin. Motor may need a flick to start it spinning.

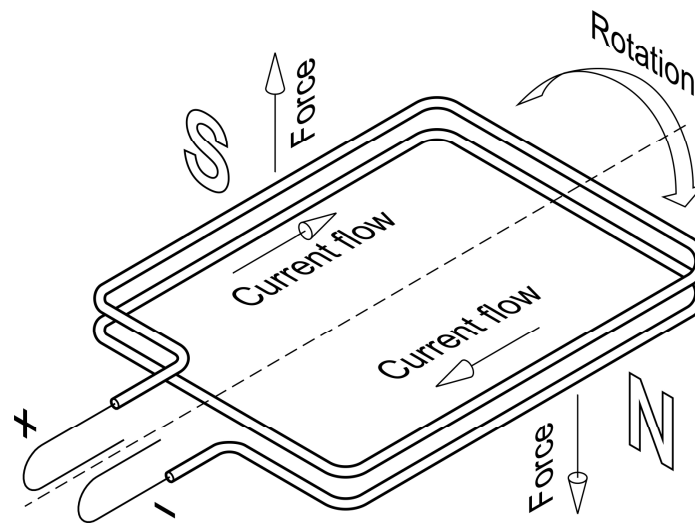

## Why the Motor Turns:

The two magnets are North and South poles facing each other so that a magnetic field is present in the air space between the faces of the two magnets.

The rotor can be wound in several ways as shown later in this instruction sheet, but the principles are the same. In a simple single coil rotor, the current passes in from the positive brush wire, through the commutator and coil and out from the negative brush wire.

For the rotor to be forced to turn, the magnetic field of the magnets must react with the magnetic field caused by the current through the bundle of wires so that it pushes both bundles on opposite sides of the rotor vertically out of the magnetic field.

When the rotor has rotated one half turn and the opposite coil bundle is in front of the same pole magnet, the brushes touch the opposite commutator loop and the current is suddenly reversed in the coil. Immediately the coil bundles are pushed out of the magnetic field in the same direction. The 'Hodson' motor has only two coil bundles in front of magnets at any time, so the rotational momentum of the rotor must continue the rotation through the places where there are no turning forces. In a real motor there are many coils and there are always several coils in the magnetic field at any time so the rotational force is continuous.

For maximum efficiency, as the coil bundle approaches the magnet, the bundles are first attracted into the magnetic field and, when they are passing half way across the face of the magnets, the current is reversed and they are then pushed out of the same field.

Pull or push must be UP on one side of the rotor and the pull or push must be DOWN on the opposite side of the rotor therefore the current through the bundles on either side of the rotor must be flowing in the opposite directions. As the rotor turns a half turn, the current must be reversed very quickly in the coil while the rotor is turning and this reversal of the current through the rotor coil is the function of the commutator.

It can be seen that the position of the commutator loops on the rotor is very important for the current to reverse at exactly the right moment for the motor to run efficiently.

## Types of rotor windings:

**Simple single coil rotor winding (as shown on the assembly cards in the kits).**

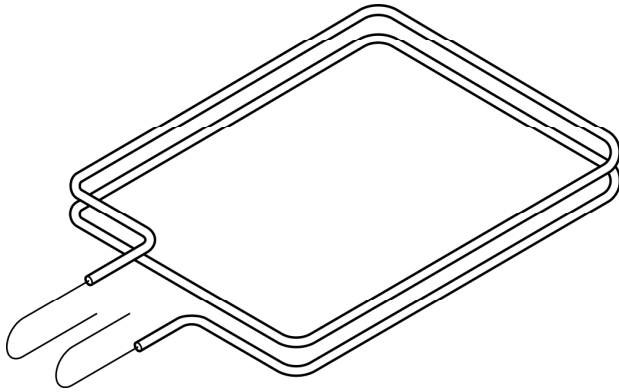

The two wire bundles pass each of the magnets once per turn therefore, if current is flowing through the wire in the correct direction as the bundle passes the magnet, there are 2x pushes on the rotor wire bundles per turn. The current through the wire bundles must flow in the correct direction, therefore it is very important that the commutator loops are positioned correctly relative to the coil bundles and, for a single coil, they should be positioned in line with each bundle. By turning the rotor slowly and starting at the commutator loops, trace the path of the current through the coils and check that a wire bundle is in front of a magnet when current is flowing through that bundle.

## Double coil rotor winding:

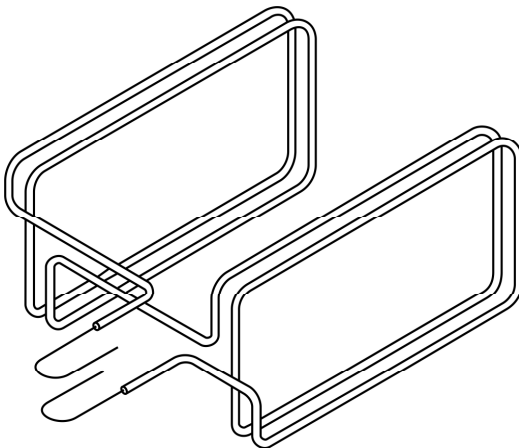

The four wire bundles pass each of the magnets once per turn therefore, if current is flowing through the wire in the correct direction as the bundle passes the magnet, there are 4x pushes on the rotor wire bundles per turn. The current through the wire bundles must flow in the correct direction, therefore it is very important that the commutator loops are positioned correctly relative to the coil bundles and, for a double coil, they should be positioned between the bundles. By turning the rotor slowly and starting at the commutator wires, trace the path of the current through the coils and check that a wire bundle is in front of a magnet when current is flowing through that bundle.

## Four Coil Rotor Winding:

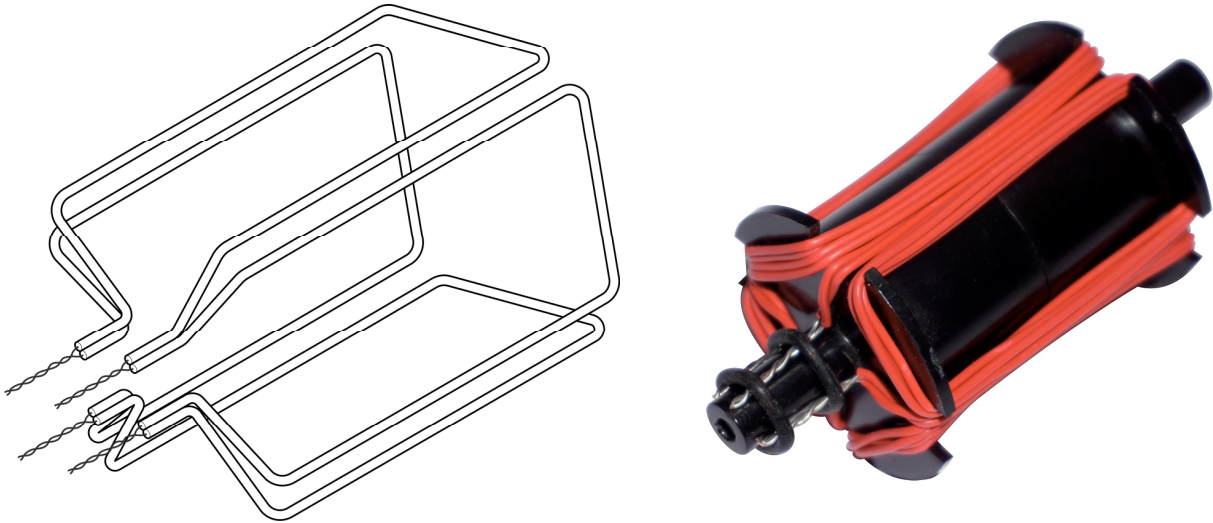

For simplicity and clarity, the sketch above shows only one turn per coil, but each coil would normally be of 5 or 6 turns.

The four wire bundles pass each of the magnets once per turn therefore, if current is flowing through the wire in the correct direction as the bundle passes the magnet, there are 4x pushes on the rotor wire bundles per turn. The current through the wire bundles must flow in the correct direction, therefore it is very important that the commutator twisted connections are positioned correctly relative to the coil bundles and they should be positioned in line with each bundle. By turning the rotor slowly and starting at the commutator wires, trace the path of the current through the coils and check:

- If all the wires in any bundle are carrying current in the one direction
- That a wire bundle is in front of a magnet when current is flowing through that bundle.

Notice that the 4 coil rotor provides 4 commutator connections instead of two. This results in a smoother rotation and better and more reliable starting.

## The Commutator:

In the single and double coil rotors, the instructions say that the 'loops' of bare wire be held to the bearing tube of the rotor rather than a single bare wire. It is important that current is flowing through the coil while the coil is entering and leaving the magnetic fields in front of the magnets. The current should be flowing while the rotor is turning almost a half turn and the brushes will remain in contact only if a loop is used rather than a single bare wire. The time that the brushes are not contacting the loops should be small.

Experiment with different shapes and positions of the loops around the tube to obtain the best starting, power and speed. When best performance is found, examine when the commutator is reversing the current through the coil relative to the position of the coil bundles.

## Helpful Hints for Winding the Coils:

Always allow a few centimetres of spare wire at the start and finish of the coil to be trimmed off later. A most important point when inspecting a winding is that the current passing through any bundle of wire must be flowing in the opposite direction to the bundle on the opposite side of the rotor.

### Single coil winding.

Wind the coil of about 10 to 12 turns across the diameter of the rotor with half the turns split either side of the bearing tube. Direction of winding does not matter.

Bring both the start and finish wires out the same end of the rotor. Cut the wires to be about 10mm past the end of the rotor bearing tube.

Using the Alligator clip, skin about 25mm of plastic from each wire. Fold a loop about 4mm wide and 10mm long in each bare wire and press the extra wire back to the face of the rotor so the bare loops lay along the bearing tube opposite each other but in line with the bundles of wires on the rotor. Do not allow the loops to protrude past the end of the bearing tube. See previous illustrations.

Take the small rubber rings, stretch them over the bearing tube and over the loops to hold them tightly to the tube. Roll the first ring right back into the corner and position the second ring on the end of the tube, leaving the maximum space between the rings for the two brushes to rub against the loops (the commutator).

### Double coil winding.

Wind one coil of about 10 to 12 turns between adjacent notches in the rotor (the winding bundle is like a chord to the circular shape). Then turn the rotor 180° so that the opposite side of the rotor is facing you. Continue to wind the same number of turns in the opposite direction between adjacent notches so that the two coils are on opposite sides of the rotor. The initial direction of winding does not matter providing that the two coils are wound in the opposite direction when looking directly at each one.

Bring both the start and finish wires out the same end of the rotor. Cut the wires to be about 10mm past the end of the rotor bearing tube.

Using the Alligator clip, skin about 25mm of plastic from each wire. Fold a loop about 4mm wide and 10mm long in each bare wire and press the extra wire back to the face of the rotor so the bare loops lay along the bearing tube opposite each other but between the two coils. Do not allow the loops to protrude past the end of the bearing tube.

Take the small rubber rings, stretch them over the bearing tube and over the loops to hold them tightly to the tube. Roll the first ring right back into the corner and position the second ring on the end of the tube, leaving the maximum space between the rings for the two brushes to rub against the loops.

### Four coil winding.

Wind one coil of about 5 or 6 turns between adjacent notches in the rotor in the same way as the double coil. When finished, turn the rotor 90° and take the wire 25mm past the end of the bearing tube, double it back tightly on itself and continue to wind the same number of turns starting in the same notch but wind the coil between the notch you have just wound and the next empty notch on the rotor.

After second coil is finished, again form a tight loop in the wire and wind it back into the same notch to wind the next coil into the next notch. The initial direction of winding does not matter providing that, when facing each coil, the windings are all wound in the same direction.

Cut the 4 loops about 10mm past the end of the bearing tube and, using the alligator clip, skin the plastic for about 20mm. Twist the pairs of bare wires together tightly and lay the 4 twisted wires against the bearing tube **in line with each coil bundle**. Do not allow the twisted wires to protrude past the end of the bearing tube.

Take the small rubber rings, stretch them over the bearing tube and over the twisted wires to hold them tightly to the tube. Roll the first ring right back into the corner and position the second ring on the end of the tube, leaving the maximum space between the rings for the two brushes to rub against the 4 sets of twisted wires.



## Experiments:

### Motor Current Changes With Load:

Connect a 5 amp Student Meter in series with a 2V.DC. power source (an IEC power supply set to 2V.DC.). Run the motor and measure the current flow through the brushes.

Gently place your finger or a piece of cardboard on the spinning bearing (opposite end to the commutator) to slow down the motor a little and notice the current rise when the motor is loaded.

Stop the motor with the fingers and measure the current flow through the brushes. Again make the motor run and notice the reduction in current.

All normal motors behave this way. It can be seen that if power is applied to a real motor but it is jammed and cannot rotate, a large current flows, a fuse might blow or damage to the motor or wiring can occur.

#### Notes:

- If excessive current is permitted to flow through the brushes and commutator, the wire will become hot and might melt or damage the plastic rotor.
- A simple uncalibrated ammeter, which is quite suitable for this experiment, can be made from this motor kit. It is described in a later experiment.

### Energy From the 'Hodson' Motor:

Using small piece of adhesive tape, attach a length of thread 1500mm long to the rotor tube at the opposite end to the commutator. Lay the motor on its side at the edge of a bench so that the thread hangs down to the floor and free of obstructions. Tie a small mass to the end of the thread and connect the motor to the power supply. Have some slack thread on the floor. Get the motor spinning while the thread is slack.

As soon as the mass begins to lift from the floor, use a stopwatch to measure the time it takes to lift a mass (say 10 grams) from the floor a certain distance (say 1 metre).

Repeat the experiment 3 times and obtain an average. Calculate the power of the motor in Watts.

Try using lighter and heavier weights.

### A Simple AC Motor:

There are many different types of AC motors. A 'Synchronous' motor is a type that spins at a speed exactly locked in with the 50Hz supply frequency. A two pole (2 magnet) motor will spin at exactly 50 Revolutions Per Second or 3000 Revolutions Per Minuter (RPM). A four pole motor will spin at exactly 1500 RPM, a six pole motor is 1000 RPM, a twelve pole motor is 500 RPM and so on.

A real AC motor does not have a commutator and the current through the windings is therefore not reversed. The 'Hodson' motor will run as a 'Synchronous Motor' if connected to a low voltage AC supply. The motor must be started by spinning the armature briskly with the fingers to rotate it at 'synchronous speed'. This 'spinning up to speed' can be a little difficult and might take some practice but when the 'Synchronous' speed is made, the rotor speed will 'lock-in' to this exact speed.

Check the speed with an IEC Stroboscope (either Xenon type or small LED type) and prove the above explanations. You will find the above explanation is not correct for the 'Hodson' motor !

#### Explanation:

If the AC current through the rotor coil is at 50Hz, the current into the brushes is reversing 100 times per second. But remember that the current is also reversed through the coil by the commutator each half turn of the rotor. So, for a 'Hodson' motor to be synchronous and for the magnetic forces to be always turning the motor the same direction, the correct side of the coil carrying the current in the same direction all the time must be in front of the correct polarity pole. Therefore the rotor must rotate one half turn in  $1/50^{\text{th}}$  second. Therefore 'synchronous speed' for a 2 pole 'Hodson' motor, on AC at 50 Hz frequency, is only 1500 RPM.

## A Simple DC Dynamo:

A Dynamo is another name for a Generator. It is a machine that can make electricity from mechanical effort. Disconnect the motor from the power supply, connect the brushes to a sensitive centre-zero bench meter or galvanometer and, using the axle tube at the opposite end to the brushes, rapidly spin the armature with the fingers. A small current (Direct Current) will be seen to flow. At low rotational speeds, the pulsing nature of the DC current can be easily observed. Although it pulsates, it does not reverse therefore it is DC current, not AC (Alternating Current).

- Spin the rotor in the opposite direction and observe the result on the meter. Take note of the direction of rotation and the direction of the current flow into the meter.
- Turn one magnet over so that both magnets are now the same polarity. Mark the magnet you turned with a marker pen. Spin the rotor **in the same direction** as before and observe the result on the meter.
- Now turn the **other magnet** over so the original North is now South pole and the original South is now North pole. Spin the rotor **in the same direction** as before and observe the result on the meter.

Explain your observations.

## A Simple AC Dynamo:

Wind a single coil rotor but have the start at one end of the rotor and the finish at the other end. Cut and skin the plastic as normal but wrap a small piece of aluminium foil around the axle tube with the bare wire underneath it. Fit 2 small rubber rings to each end to hold the 2 foils tightly to the bare wire at each end of the rotor for good electrical connection.

These connections at each end of the rotor are called 'slip rings' instead of commutator because they do not reverse the current through the coil as the rotor turns.

Make a single brush at each end of the motor instead of 2 brushes at the one end, connect a sensitive centre-zero meter and flick the rotor with your finger so that it spins a few turns.

Notice that the current from the brushes is not pulsating in the one direction but is now alternating in either direction. The dynamo is generating AC current

## A Simple Ammeter:

If you inspect inside a voltmeter or an ammeter, you will find that it has the same construction as the 'Hodson' motor. There is a single coil on a rotor and a two pole magnet around the rotor. The difference is that the rotor is stopped from turning by small springs around the axle. The rotor tries to spin but the springs allow it only to deflect a small distance and then stop. As the rotating forces increase, the rotor deflects further against the springs. The pointer is fixed to the rotor to show how far the rotor has deflected.

To make an ammeter, wind a single coil and bring the start and finish wire out opposite ends. Wind the start and finish wire of the coil three or four turns tightly around each axle tube and then release them to unwind naturally so that they look like and behave like springs over the axle tubes. Each 'spring' should be wound in the opposite direction so that they are reacting against one another. The rotor must be positioned so the two wire bundles are directly in front of each magnet and the **brushes are lightly touching** the commutator loops. After the 'springs are formed, the wire passes out through one of the holes in the end plate at each end of the motor.

When current passes through the brushes into the coil, the coil tries to turn but only deflects. This deflection will occur in the opposite direction if the current is reversed through the coil.

A small meter pointer can be made from a piece of wire and can be taped to the rotor to stand up vertically while the two coil bundles are directly in front of the magnets.

To make the meter work, connect it to a DC power supply in series with a rheostat of about 15 ohms. As the current is varied through the meter, the needle will swing to show that the deflection can be altered by varying the current. Reversing the current reverses the deflection.

It can be demonstrated also that the DC meter will not operate on AC because it tries to reverse its rotational direction each 1/100<sup>th</sup> of a second and just vibrates slightly without actually deflecting.



## Real Motors:

Real motors have component parts with the same names as the 'Hodson' Motor Kit. ROTORS in real motors are made from iron and there are many COILS or windings around the rotor wound in small slots in the iron. Each coil starts and finishes at a COMMUTATOR bar made from copper and there are many commutator bars forming a ring at one end of the rotor. Each bar is insulated from the next bar with an insulation material called Mica.

The BRUSHES are usually made from carbon and have springs behind them to make them rub firmly to make good electrical connection on the commutator to reverse the direction of the current through the coils as the rotor turns. In some motors, the brushes are fixed opposite one other but the pair of brushes can be adjusted a little around the commutator so that the best operating point can be set and the brushes then locked into place.

There are many types of real motors and the type that is closest to the 'Hodson' Motor Kit is called a 'Wound Rotor' motor. The magnets on either side of the rotor are sometimes permanent magnets like the Motor Kit but often the magnetic field is created by coils wound either side of the rotor that make electro magnets rather than permanent magnets.

## Various Types of Real Motors: A General Discussion.

The moving part of a real motor is called the 'Armature' or 'Rotor' and the stationary part is called the 'Stator' or 'Frame'. The moving part usually rotates inside the Stator and usually a shaft protrudes from one end of the Frame. But sometimes it is the opposite. Notice a ceiling fan that rotates slowly to stir up the air in a room? In this case the outside part is the Rotor and the Stator is stationary and is attached to the ceiling.

It is a very complex subject and we cannot discuss all the details of all the different types of motors in this instruction sheet, but here is a brief description of several different types of motors that are manufactured for different purposes.

## AC Motors:

**Squirrel Cage Induction Motors** are the most common type of AC motor and they are found everywhere. There are Squirrel cage split phase types as used in washing machines, dryers, pumps and many appliances, Squirrel Cage capacitor start types for when high starting torque is required, Squirrel Cage shaded pole types as used in low power applications like small motors for fans etc.. All these types of motor do not have a commutator and can run for many years without any attention.

**Wound Rotor Induction Motors** are used for larger type motors driving larger machinery. Some are so large that a person can stand inside them and the windings are made from copper bar instead of wire and can sometimes require hundreds of amps to run them. This type of motor has 'Slip Rings' to make electrical connection to the rotor windings. Slip rings are similar to a commutator on the rotor but they do not reverse the direction of the current through the windings.

**Synchronous Motors** run at an exact speed that is determined by the frequency of the AC power source (usually 50Hz) and the number of pairs of magnetic poles. Very small Synchronous motors have permanent magnets on the rotor (like the 'Hodson' motor has on the stator) and AC windings on the stator. They are used in clocks where the speed must never change. Larger synchronous motors are used in machinery where constant speed is very important. Large synchronous motors cannot start from zero speed. They must be run up almost to full speed by another motor before they can be turned on. These large motors do not use permanent magnets but the rotor has windings that are fed by separate DC power through slip rings to make a very strong DC magnetic field. This field 'locks-in' to the AC field in the stator to make the rotor turn at exactly 'Synchronous speed'.

**Universal Motors** or **Series Motors** are used in kitchen appliances, portable power tools and thousands of other devices. They can operate on either AC or DC power and normally run at very high speeds and give high output power from a very small physical size. As they are loaded more and more, they create greater and greater torque. This makes them excellent for portable power tools. These motors have a commutator the same as a DC motor and the windings on the rotor are connected in series with the windings on the stator. This is why they are sometimes called Series Motors.

## DC Motors:

The 'Hodson' electric motor is a very low power DC motor with very low efficiency. The magnetic field must pass through air from one side to the other thus making the magnetic field very weak. Most real DC motors are similar in design but have an iron rotor with a very small (maybe 0.5mm) 'air gap' between the rotor and the stator to provide a very strong magnetic field. If the field is strong the efficiency is high and they have many windings and many connections in their commutators so that many bundles of wire are being pushed and pulled in and out of the strong magnetic field at any instant.

Smaller type DC motors sometimes have permanent magnets for the magnetic field. The small **Permanent Magnet** types are found in motor car windscreen wipers, heaters, electric windows, in children's toys, in battery powered tools, wheelchairs, etc.

Larger types of DC motor require a separate DC power source to create adjustable electromagnetic fields on coils (called field coils) in the stator. The commutator has many thick copper bars to carry the current to many rotor windings wound in slots in the iron rotor. The brushes are special carbon blocks that press against the commutator bars. There are many configurations of DC motor that give the motors special characteristics. There are **Series Wound** motors, **Shunt Wound** motors, **Compound Motors** (part series and part shunt) and more.

Since the world's electricity was all DC many years ago, the DC motors that were used for all purposes were refined to become a very efficient machines. Nowadays DC motors are rarely used in large industry but they have found special uses in battery operated machines and in computers that run in a digital manner. Maybe one day special high efficiency DC motors will be used to drive our motor vehicles.

Today's applications for small DC motors include office printers, hair dryers, toys, computers, compact disc drives, tape recorders, robots and thousands of other devices.

Where exact speed control is required, a special type of DC motor called a **Servo Motor** is used and where exact positioning is required, another type called a **Stepper Motor** is used. Steppers turn an exact fraction of a turn each time a pulse of current is applied so that if 100 pulses make one turn and if they are given say 1563 digital (on/off) pulses, the rotor turns **exactly** 15.63 times and stops. Again there are many configurations of this type of motor.

The DC power and pulses for this type of motor is created electronically with special circuits and microprocessors.

## DC Generators:

When DC motors of most types are driven by say another motor or a petrol or diesel engine, they make DC electricity and become a generator. For generators to run at best efficiency, their construction is a little different from the normal DC motor, but the principles are the same.

When the rotor coils are turned through the magnetic field in the stator, a DC voltage is created and the DC current can be delivered through the commutator to the brushes.

At the end of the 19th century, when power was first brought to homes to operate lights and appliances, it was all DC. Later, it was discovered that there was a huge financial advantage to distribute power at very high voltage and low current and step it down to low voltages with transformers at the place that the people needed the power. Of course, transformation cannot be done with DC power, thus AC power generation became much more popular until gradually large DC motors and generators have become almost rare.

You all know and love the famous 'Hodson' Light Box & Optical Kit and you now are using the 'Hodson' Electric Motor Kit.

IEC has also the unique 'Hodson' Induction kit where students can quickly build their own iron cores and wind their own coils to create low voltage (safe) transformers and inductors (chokes), Squirrel Cage Induction Motor, simple DC motor, AC and DC magnets and more. They will really discover electro-magnetics and will understand induction, transformer theory, motor theory, efficiency and 'losses' in iron and copper, magnetic damping, eddy currents, inductive heating and much more.

Ask your favourite dealer for this item.

Designed and manufactured in Australia

**INDUSTRIAL EQUIPMENT & CONTROL PTY. LTD.**

61-65 McClure St. Thornbury. 3071 Melbourne. Australia

Tel: 61 (0)3 9497 2555 Email: [iec@iecipl.com.au](mailto:iec@iecipl.com.au) [www.iecipl.com.au](http://www.iecipl.com.au)

1 2